



**PFAFF**<sup>®</sup>

# performance Quilt

## “Delft Blue” Tulip Quilt

The Dutch countryside, with its tulips and windmills, has been the inspiration for this enchanting quilt. Original fabrics used for this piece are one-of-a-kind reproduction prints of traditional Delft earthenware. While this quilt looks especially elegant in Delft blue and white, it is equally stunning using the fresh, vibrant colors of spring tulips for which Holland is so famous.

Quilt size: 49½" x 49½" (126 x 126 cm)

### Fabric requirements:

- Fabric A – 1 1/8 yds (1.0 m) LIGHT / White background with blue flower print
- Fabric B – 3/8 yd (0.35 m) MEDIUM / Medium blue
- Fabric C – ¼ yd (0.2 m) MEDIUM LIGHT / Light blue
- Fabric D – ½ yd (0.5 m) DARK / Dark blue
- INNER BORDER – ¼ yd (0.25 m) Fabric B / Medium blue
- MIDDLE BORDER – ½ yd (0.5 m) Light border print
- OUTER BORDER & BACKING & BINDING – 3 ¼ yds (3.0 m) Dark blue tone-on-tone print
- BATTING – 54" x 54" (140 x 140 cm)

## Supplies:

- ¼" Quilting Foot with IDT #820211096
- Rotary Cutter, Ruler and Mat
- Marking Pencil
- Cotton Sewing Thread

## Cutting instructions

NOTE: Cut all strips selvage to selvage unless otherwise noted.

All rotary cutting dimensions include ¼" (6 mm) seam allowances.

### From Fabric A – LIGHT:

- 1 - 3½" (9 cm) strip  
Sub-cut into 12 - 3 ½" (9 cm) squares
- 2 - 3 7/8" (10 cm) strips for Step 1A  
Sub-cut into 20 - 3 7/8" (10 cm) squares
- 2 - 3 7/8" (10 cm) strips for Step 1B  
Sub-cut into 14 - 3 7/8" (10 cm) squares
- 1 - 3 7/8" (10 cm) strips for Step 1C  
Sub-cut into 8 - 3 7/8" (10 cm) squares
- 4 - 2" (5 cm) strips for 4-patch units
- 1 - 2" (5 cm) strip  
Sub-cut into 4 - 2" x 3½" (5 cm x 9 cm) rectangles and 4 - 2" (5 cm) squares
- 1 - 3½" (9 cm) strip  
Sub-cut into 4 - 3½" (9 cm) squares.  
Cut squares once diagonally to yield 8 triangles

### From Fabric B – MEDIUM:

- 1 - 3½" (9 cm) strip  
Sub-cut into 8 - 3½" (9 cm) squares
- 2 - 3 7/8" (10 cm) strips for Step 1A  
Sub-cut into 20 - 3 7/8" (10 cm) squares

### From Fabric C – LIGHT/MEDIUM:

- 1 - 3 7/8" (10 cm) strip for Step 1C  
Sub-cut into 8 - 3 7/8" (10 cm) squares

- 1 - 2" (5 cm) strip  
Sub-cut into 4 - 2" (5 cm) squares

### From Fabric D – DARK:

- 2 - 3 7/8" (10 cm) strips for Step 1B  
Sub-cut into 14 - 3 7/8" (10 cm) squares
- 4 - 2" (5 cm) strips for 4-patch units
- 1 - 1" (2.5 cm) strip  
Sub-cut into 4 - 1" x 5" (2.5 cm x 12.5 cm) rectangles

### INNER BORDER:

- 4 - 2" (5 cm) strips

### MIDDLE BORDER:

- 6 - 2¾" (7 cm) strips

### BACKING:

- 1 - 54" x 42" (140 cm x 110 cm)
- 1 - 54" x 14" (140 cm x 36 cm)

### OUTER BORDER:

- 4 - 3½" (9 cm) strips x remaining length

### BINDING:

- 4 - 2 ½" (6.5 cm) strips x remaining length

## Step 1

### STEP 1A

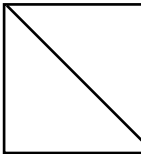
- Using the marking pencil draw a diagonal line on the wrong side of the 20 - 3 7/8" (10 cm) Fabric A squares. 
- Place the 3 7/8" (10 cm) Fabric B squares right sides together with the Fabric A squares.
- Thread your machine with sewing thread in the top and bobbin. Attach the ¼" Quilting foot.
- Sew a ¼" (6 mm) on each side of the drawn line.

- Cut apart on the drawn line. This will result in 40 half-square triangles.
- Press the half-square triangle units CLOSED first and then press the seam toward Fabric B.
- The half-square triangle unit will measure  $3\frac{1}{2}'' \times 3\frac{1}{2}''$  (9 cm x 9 cm).

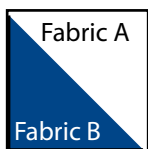

### STEP 1B

- Using the marking pencil draw a diagonal line on the wrong side of the  $14 - 3\frac{7}{8}''$  (10 cm) Fabric A squares.
- Place the  $3\frac{7}{8}''$  (10 cm) Fabric D squares right sides together with the Fabric A squares.
- Sew a  $\frac{1}{4}''$  (6 mm) on each side of the drawn line.
- Cut apart on the drawn line. This will result in 28 half-square triangles.
- Press the half-square triangle units CLOSED first and then press the seam toward Fabric D.

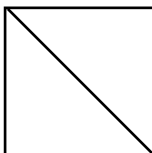

### STEP 1C

- Using the marking pencil draw a diagonal line on the wrong side of the  $8 - 3\frac{7}{8}''$  (10 cm) Fabric A squares.
- Place the  $3\frac{7}{8}''$  (10 cm) Fabric C squares right sides together with the Fabric A squares.
- Sew a  $\frac{1}{4}''$  (6 mm) on each side of the drawn line.
- Cut apart on the drawn line. This will result in 16 half-square triangles.
- Press the half-square triangle units CLOSED first and then press the seam toward Fabric C.

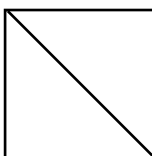

blocks. What makes this version so appealing is the wonderful movement it creates in the center of the quilt, with the secondary interlocking windmill designs that appear when you set the blocks next to each other. And no quilt from Holland would be complete without turning windmills!

### Construct Block A / Dutch Windmill

- You will need 4 (four) Dutch Windmill blocks.
- To construct each Dutch Windmill block you will need:
  - 1 -  $3\frac{1}{2}''$  (9 cm) Fabric B square
  - 1 -  $3\frac{1}{2}''$  (9 cm) Fabric A square
  - 3 - Fabric A & D half-square triangle units
  - 4 - Fabric A & C half-square triangle units
- Lay out block as shown in the diagram
- Assemble block
- Block will measure  $9\frac{1}{2}'' \times 9\frac{1}{2}''$  (24.5 x 24.5 cm) unfinished
- Repeat the steps above and make a total of 4 (four) Dutch Windmill blocks

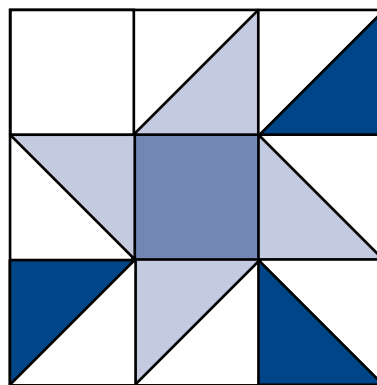

### Step 3

This block is a slight variation of the traditional Railroad block. After adding a half-square triangle block to one corner, it was renamed "Dutch Railroad" to depict that wonderful high-speed bullet train gliding past beautiful churning windmills on the way to Amsterdam.

### Construct Block B / Dutch Railroad

- You will need 8 Dutch Railroad blocks.
- To construct each Dutch Railroad block you will need:

## Step 2

There are many variations of Dutch Windmill

- 1 - Fabric A & D half-square triangle unit
- 4 - Fabric A & B half-square triangle units
- 4 - Fabric A & D four-patch units

To construct the 3½" (9 cm) Fabric A & D four-patch units:

- Place the 2" (5 cm) Fabric A and Fabric D strips right sides together
- Sew ¼" (6 mm) seam on the long side of strip unit
- Press strip closed, then open and press seam toward Fabric D
- Repeat process with three remaining 2" (5 cm) Fabric A & D strips
- Cut into 64 - 2" (5 cm) units
- Rotate one unit and place right sides together on top of another unit, butting seams together
- Sew two units together to form a four-patch square
- Press each unit closed, then open and press seam to one side
- Four-patch unit should measure 3½" (9 cm) square
- Make a total of 32 - 3½" (9 cm) four-patch units



- Lay out block as shown in the diagram
- Assemble block
- Block will measure 9½" x 9½" (24.5 x 24.5 cm) unfinished
- Repeat steps above and make a total of 8 Dutch Railroad blocks

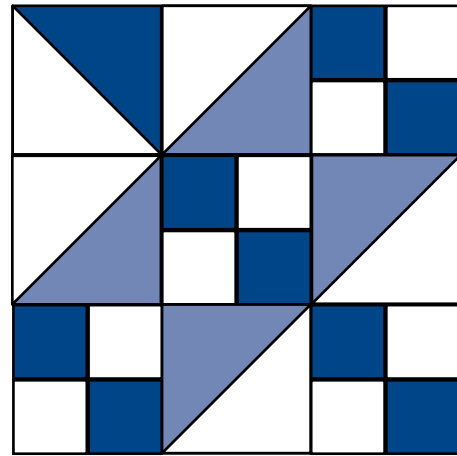

## Step 4

Quite possibly more than anything else, Holland is famous for tulips, with flowering fields stretching for miles and miles along the countryside like brilliant ribbons of breathtaking color! In the springtime, no matter where you go in the Netherlands, you can enjoy their unparalleled beauty. The traditional tulip block was the perfect finishing touch to this quilt!

### Construct Block C / Dutch Tulip

- You will need 4 Dutch Tulip blocks.
- To construct each Dutch Tulip block you will need:
  - 1 - 3½" (9 cm) Fabric B square
  - 2 - Fabric A & B half-square triangle units
  - 2 - Fabric A & D half-square triangle units
  - 1 - Fabric A & D stem block
  - 1 - Fabric A & C tulip bud unit

To construct the 3½" (9 cm) Fabric A & D stem unit:

- Sew a 1" x 5" (2.5 x 12.5 cm) Fabric D rectangle to a triangle cut from a 3½" (9 cm) Fabric A square
- Carefully press the seam toward the Fabric D rectangle
- Sew another Fabric A triangle to remaining long side of the Fabric D rectangle
- Press the seam toward the Fabric D rectangle
- You will need to trim edges of Fabric D stem and square up units

- Unit should look like diagram below and measure  $3\frac{1}{2}'' \times 3\frac{1}{2}''$  (9 x 9 cm)
- Make a total of 4 (four) stem units

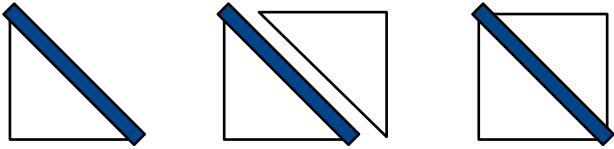

To construct the  $3\frac{1}{2}''$  (9 cm) Fabric A & C bud unit:

- Sew 1 -  $2''$  (5 cm) Fabric A square right sides together with 1 -  $2''$  (5 cm) Fabric C square
- Make 4 units as shown in the diagram



- Sew 1 -  $2'' \times 3\frac{1}{2}''$  (5 x 9 cm) Fabric A rectangle right sides together with the unit above
- Make 4 units EXACTLY as shown in the diagram, carefully following fabric placement
- Each unit will measure  $3\frac{1}{2}'' \times 3\frac{1}{2}''$  (9 x 9 cm)

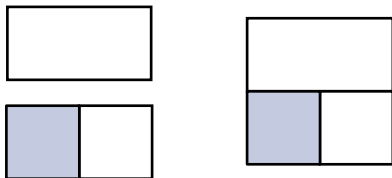

- Lay out block as shown in the diagram
- Assemble block

- Block will measure  $9\frac{1}{2}'' \times 9\frac{1}{2}''$  (24.5 x 24.5 cm) unfinished
- Repeat the steps and make a total of 4 (four) Dutch Tulips blocks

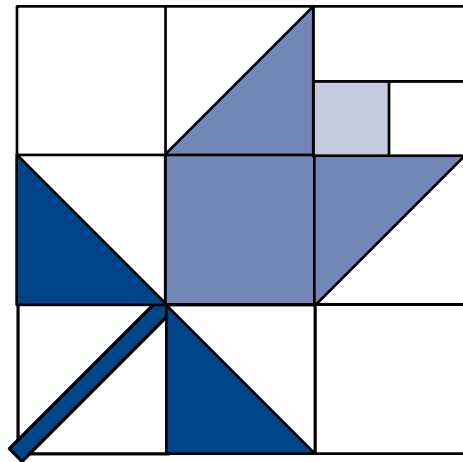

## Step 5

- Assemble blocks according to quilt layout as shown, being careful to rotate blocks to achieve desired interlocking design
- Add  $2''$  (5 cm) Inner border strips and press seams toward border
- Add  $2\frac{3}{4}''$  (7 cm) Middle border strips and press seams toward border
- Add  $3\frac{1}{2}''$  (9 cm) Outer border strips and press seams toward outer border
- Layer quilt top, batting and backing
- Quilt as desired
- Finish your quilt with the  $2\frac{1}{2}''$  (6.5 cm) binding

